

Moisture meter

# User manual

## FSO

Online whole grain moisture measuring system



78,0 °F | 6,16% | 456kg/m<sup>3</sup> | -27,3td | 0,64aw | 51,9%r.H. | 14,8%abs | 100,4g/m<sup>2</sup> | 09m/s | 4,90Ug/L | 1

## Overview of your FSO

### Overview measuring device

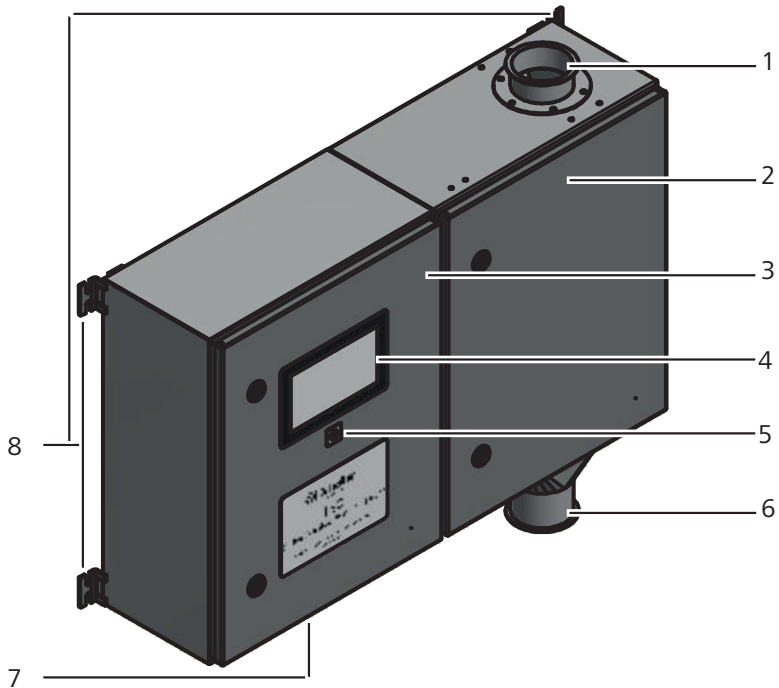

No	Name
1	Inlet hole (Jacob DN80)
2	Control cabinet with measuring device
3	Control cabinet with electronics
4	Display and control (touch display)
5	Power on button
6	Outlet hole (Jacob DN80)
7	Connections (underneath)
8	Installation brackets (on all four corners)

## Overview measuring device



No	Name
1	Inlet hole (Jacob DN80)
2	Control cabinet with measuring device
3	Outlet hole (Jacob DN80)
4	Connections
5	Main switch
6	Power on button
7	Display and control (touch display)
8	Control cabinet with electronics
	Installation brackets on all four corners (not numbered)

## Overview levels

There are three different levels of the device: Home, measuring window and main menu :

### Overview Home



No	Name
1	Main menu
2	Time and date
3	Software version number
4	Measuring

## Overview measuring window

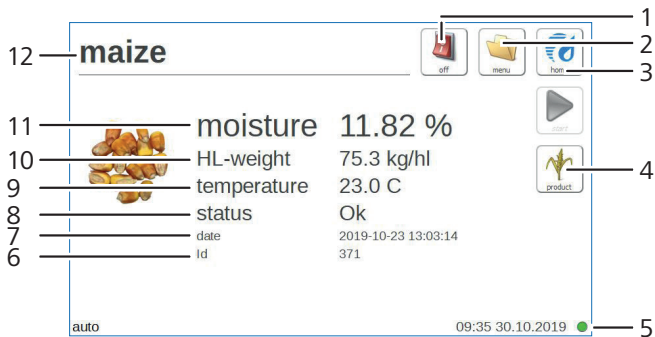

No	Name
1	Turn off the device
2	Main menu
3	Home
4	Product selection
5	Time and date / Network status display
6	Continuous measurement numerator
7	Date and time of the last measurement
8	Status
9	Temperature of the measured material
10	Hectolitre weight of the measured material
11	Moisture of the product to be measured
12	Product name

Overview main menu

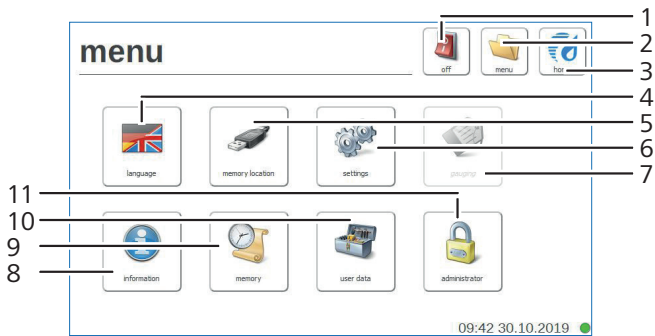

No	Name
1	Turn off the device
2	Main menu
3	Home
4	Language
5	Memory location
6	Settings
7	Gauging (not available)
8	Information
9	Memory
10	User data
11	Administrator

---

## Inhaltsverzeichnis

<b>Overview of your FSO .....</b>	<b>2</b>
Overview measuring device .....	2
Overview measuring device .....	3
Overview levels .....	4
<b>1. Introduction .....</b>	<b>10</b>
1.1 Information about this user manual .....	10
1.2 Limitation of liability .....	10
1.3 Symbols used in this manual .....	10
1.4 Customer service .....	11
<b>2. For your safety .....</b>	<b>12</b>
2.1 Proper use .....	12
2.2 Improper use .....	12
2.3 User qualifications .....	12
2.4 General safety information .....	13
<b>3. First steps .....</b>	<b>13</b>
3.1 Unpack the device .....	13
3.2 Checking the delivery content .....	13
3.3 Remove the transport protection .....	14
3.4 Mount the transport protection .....	15
3.5 Installation instructions .....	15
3.6 Mechanical installation .....	16
3.7 Electrical connection .....	16
<b>4. Using the device - Basics .....</b>	<b>19</b>
4.1 Turn on the device .....	19
4.2 Take a measurement .....	19
4.3 Turn off the device .....	19
<b>5. Measurement .....</b>	<b>20</b>

5.1	Take a measurement .....	20
5.2	View all measured data (data memory) .....	21
5.3	Delete all measured data (data memory) .....	21
<b>6.</b>	<b>Products and calibration curves .....</b>	<b>22</b>
6.1	Definition water content .....	23
6.2	Information regarding the comparative measurement using the kiln-drying method .....	23
<b>7.</b>	<b>Data access via REST interface (OPTION) .....</b>	<b>24</b>
7.1	Identifying the network address of the device .....	24
7.2	Retrieval of measured data via browser .....	24
<b>8.</b>	<b>Handling and menus .....</b>	<b>25</b>
8.1	Set language .....	25
8.1	Define memory location .....	25
8.2	Set date and time .....	26
8.3	Set °C/°F .....	27
8.4	Device test .....	27
8.5	IR temperature .....	29
8.6	My device .....	29
8.7	Log file .....	29
8.8	Update .....	31
8.9	Auto-off time .....	31
8.10	Special products .....	32
8.11	Gauging .....	33
8.12	Information .....	33
8.13	Memory .....	34
8.14	User data .....	34
8.15	Administrator .....	34
<b>9.</b>	<b>Care and maintenance .....</b>	<b>35</b>
9.1	Cleaning the device .....	35

---

<b>10.</b>	<b>Faults .....</b>	<b>35</b>
10.1	Eventual error notifications that may occur .....	37
<b>11.</b>	<b>Transport, storage and disposal .....</b>	<b>38</b>
11.1	Transport .....	38
11.2	Storage .....	38
11.3	Disposal .....	38
<b>12.</b>	<b>Specifications of the device .....</b>	<b>39</b>
12.1	CE declaration of conformity .....	39
12.2	Technical data .....	43

## 1. Introduction

### 1.1 Information about this user manual

This user manual ensure a safe and efficient use of the FSO grain moisture instrument. The user manual is part of the instrument and must be kept in its direct environment and accessible to the user at all time.

All users are required to carefully read and make sure that they have understood this user manual. All of the safety and operating instructions detailed in this manual have to be observed to ensure the safety of the device.

### 1.2 Limitation of liability

All of the information and instructions provided in this user manual have been compiled on the basis of the current standards and regulations, the state of the art, and the extensive expertise and experience of Schaller Messtechnik GmbH.

Schaller Messtechnik GmbH does not accept any liability for damage associated with the following, which also voids the warranty:

- Non-observance of this user manual
- Improper use
- Inadequately qualified users
- Unauthorised modifications
- Technical changes
- Use of unapproved spare parts

This fast measuring procedure can be affected by a range of different factors.

For this reason, we recommend periodically checking the device's measurements with a standardised oven-drying method.

### 1.3 Symbols used in this manual

All the safety information provided in this manual is shown with a corresponding symbol.



## **WARNING**

Non-observance can lead to serious irreversible or fatal injuries.



## **CAUTION**

In case of non-observance, light or medium injuries can occur.



## **ATTENTION**

Non-observance can lead to physical damage.



## **Information**

This symbol indicates important information that enables users to use the device more efficiently and cost-effectively.

### 1.4 Customer service

For technical advice, please contact our customer service department at

Schaller Messtechnik GmbH  
Max-Schaller-Straße 99  
A - 8181 St. Ruprecht an der Raab

Telefon: +43 (0)3178 28899  
Fax: +43 (0)3178 28899 - 901

E-Mail: [info@humimeter.com](mailto:info@humimeter.com)  
Internet: [www.humimeter.com](http://www.humimeter.com)



© Schaller Messtechnik GmbH 2024

## 2. For your safety

The device complies with the following European directives:

- Restriction of hazardous substances in electrical and electronic equipment (RoHS Directive)
- Electromagnetic compatibility (EMC directive)
- Machines

The device is manufactured according to the latest technical standards. There are nevertheless certain residual dangers.

To prevent dangers, you must follow the safety instructions.

### 2.1 Proper use

- Fast measuring device for online water content determination of whole grain in bypass.
- You may only measure products which are defined in this manual (see "6. Products and calibration curves").

### 2.2 Improper use

- The device should not be used in ATEX areas.
- The FSO can only be installed in a bypass, installation in the main material flow is not permitted.
- Do not measure frozen samples or samples over +60 °C.
- The device is not waterproof (IP40), protect it from water.

### 2.3 User qualifications

Only those people who can be expected to perform the work reliably are permitted to operate the instrument. People who are affected by drugs, alcohol or medication are not permitted to use the instrument.

Persons who use this instrument must have read and understood the user manual and follow its instructions.

---

## 2.4 General safety information

Follow the safety instructions below to avoid personal injury and material damage:

- Do not open the doors of the device during operation.
- Keep the device away from children under the age of 8.

Before the delivery, all technical features of your device have been tested and carefully approved by our quality control department. Each device has a serial number and a control label. This label may not be removed.

## 3. First steps

### 3.1 Unpack the device

- Unpack the device.
- Next, make sure that it is not damaged and that no parts are missing.

### 3.2 Checking the delivery content

Use the following list to check if the delivery is complete:

- FSO incl. transport protection
- Outlet nozzles
- User manual

Optional accessories:

- FSO relay alarm function
- FSO analogue outputs for humidity and temperature
- FSO ethernet interface
- FSO REST interface
- FSO grain pre-cleaning unit
- Laboratory order for creation of calibration curves
- Entry of an already existing calibration curve into the device

### 3.3 Remove the transport protection

- When delivered, all FSO devices are provided with a transport protection (figure 1).
- Please remove it before installation.
- First remove the transport safety screw (figure 1).
- » To loosen the screw, carefully turn the device over on its backside.
- Remove the marked screw (figure 8).
- » Store the screw well, as it has to be used again for a return transport.
- Now unscrew the transport protection cover from the FSO housing. Remove the marked screws (figure 3).
- » Remove only the marked screws!
- Now screw the outlet nozzle to the FSO housing with the previously removed screws.

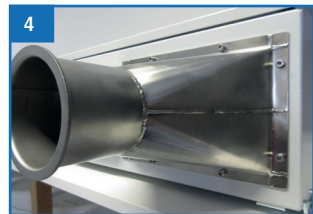
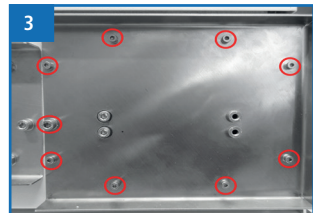
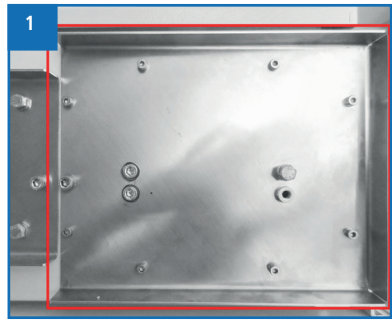

### 3.4 Mount the transport protection

- The transport protection must be remounted before each transport.
- First, remove the outlet nozzle. All nine marked screws must be unscrewed (figure 5 & 6).
- » Do not remove screws other than the marked ones.
- Now, use the previously removed screws to mount the metal sheet for the transport protection (figure 7).
- Screw the transport protection screw into one of the two insertion nuts (figure 8).
- It is important that the screw is not forcefully tightened. It should be possible to screw it in without great force.
- » Use only the original screw!
- » Should this not be possible, please contact Schaller Messtechnik GmbH.

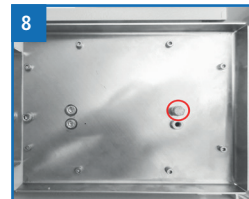
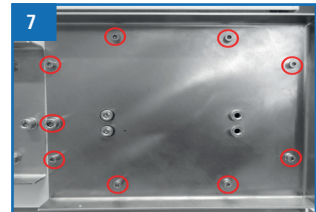
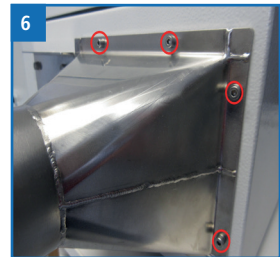
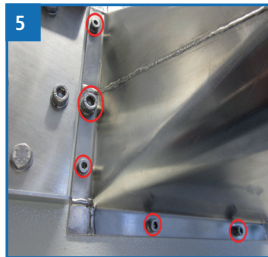

### 3.5 Installation instructions

Please follow the following instructions:

- Do not leave the device in the rain. The device is not waterproof.
- Do not install the device in humid rooms.
- Do not expose the device to extreme temperatures.
- It is important to select a place of installation that prevents condensation in the measuring chamber during operation. Please be careful if installed in a cold environment, if measuring warm material!
- The FSO may only be installed in a bypass, installation in the main material flow is not permitted.
- Avoid strong mechanical shocks or impacts.
- Do not install the device near strong electromagnetic fields.
-

### 3.6 Mechanical installation

- Mount the FSO to a wall or a support bracket using the four fastening clips.
- The device must be set up horizontally.
- Now connect the compressed air to the bottom of the FSO. Therefore a  $\varnothing 4\text{mm}$  hose connection is provided on the FSO.



#### ATTENTION

Please handle the FSO with caution during installation. There are sensitive components in the interior, which could be destroyed by mechanical influences (f.e. by dropping )!

- Now install your pipes at the inlet and outlet nozzles. The two nozzles have a DN80 pipe flange (jakob pipes).
- Material inflow or volume flow to the measuring device: max. 3.2 l/min.



#### ATTENTION

The FSO may only be installed in a bypass, installation in the main material flow is not permitted - the volume flow of 3.2 liters / minute cannot be exceeded in no case.

- Now connect the compressed air to the bottom of the FSO. Therefore a  $\varnothing 4\text{mm}$  hose connection is provided on the FSO (figure 9).
- » The FSO requires 5 bar (+/- 0.5 bar) pressure.



### 3.7 Electrical connection

In the left control cabinet there are terminal blocks for the electrical connection of the measuring device (figure 10).

Definition of cable cross section for terminal blocks:

0.5 - 4 mm<sup>2</sup> or 20 - 10 AWG

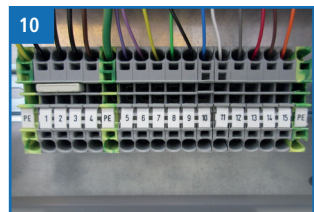

### 3.7.1 Configuration and function of the terminal block contacts

terminal blocks FSO			
earthing	PE	yellow-green	
power supply V- (GND)	X1	black	
power supply V- (GND)	X2	black	
power supply V- (GND)	X3	black	
power supply V+ 24VDC	X4	braun	
earthing	PE	yellow-green	
moisture system ready	X5	purple	
moisture system ready	X6	purple	
moisture 4-20mA	X7	yellow	
temperature 4-20mA	X8	green	
moisture/temp. GND	X9	black	
alarm moisture NC	X10	blue	
alarm moisture COM	X11	white	
alarm moisture NO	X12	grey	
alarm temperature NC	X13	red	
alarm temperature COM	X14	brown	
alarm temperature NO	X15	orange	
earthing	PE		

**Grounding (PE):** Potential equalization must be grounded to the system

**Supply V- (GND) (X1, X2, X3):** V- Negative supply voltage

**Supply V+ 24VDC (X4):** V+ Positive supply voltage (24V DC) max. 60 Watt

**Measurement ready NO (X5, X6):** The connections are used as safety switches for the material supply or outlet.

Switching capacity of the relay contact for ohmic or low inductive loads:

Switching capacity AC max.: 5 A at 250 V AC

Switching power DC max.: 10 A at 28 V DC

The terminals X5 and X6 are activated as soon as the device is ready for measurement.  
 -> Material **can be** transported to the measuring device.

If the two terminals **are not connected through, then no material** may be transported to the measuring device. This could lead to overflowing or blockage of the device by material.

**Mositure 4-20mA (X7):** Analog power output 4 to 20mA for the water content (load < 500 Ohm (UB 24 V).

**Temperature 4-20mA (X8):** Analog power output 4 to 20mA for the sample temperature (load < 500 Ohm (UB 24 V).

**Moisture/Temp. GND (X9):** Ground potential for power measurement.

**Alarm moisture NC (X10):** Alarm output when a defined moisture value is exceeded or not reached. normally closed.

**Alarm moisture COM (X11):** COM port alarm contact moisture

**Alarm moisture NO (X12):** Alarm output when the moisture level falls below or exceeds a defined moisture value. normally opened.

**Alarm temperature NC (X13):** Alarm output when the moisture level falls below or exceeds a defined moisture value. normally closed.

**Alarm temperature COM (X14):** COM connection alarm contact temperature

**Alarm temperature NO (X15):** Alarm output if a defined temperature value is exceeded or not reached. normally opened.

The moisture or temperature values for the alarm contacts (X10 to X15) can only be programmed by Schaller Messtechnik GmbH (also possible by remote service).

Switching capacity of the relay contacts X10 to X15 for ohmic or low inductive loads:

Switching capacity AC max.: 5 A at 250 V AC

Switching power DC max.: 10 A at 28 V DC

## 4. Using the device - Basics



### 4.1 Turn on the device

- Turn the main switch to position 1 (ON)
  - » The device turns on automatically after plugging in or
- Press  .
- The device will now start.
  - » This takes about 75 seconds.

### 4.2 Take a measurement

- The measurement is described in chapter "[5. Measurement](#)".

### 4.3 Turn off the device

- Press  or  .
- On the display appears the message (figure 11).
- Confirm with **Yes**.
  - » The device will now shut down, this takes about 30 seconds
- Turn the main switch to position 0 (OFF)

**11**  do you really want to switch off the system?

## 5. Measurement

### 5.1 Take a measurement



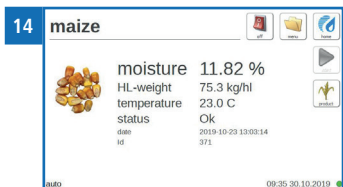
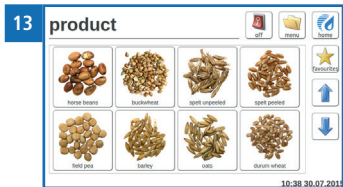
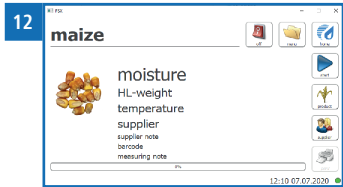

**Requirement:** On the display appears the measuring window (figure 12).

1. Press the button **Product** .
2. Now select the calibration curve you want to measure from the list of all products stored in the device (figure 13).
  - » By default, the last product entered is selected.
3. As soon as the FSO is ready for measurement, it requests material via the digital output "measurement ready". When there is enough material in the FSO, the measuring starts automatically.
  - » Once the measuring is started, the digital output "measurement ready" changes its value to 0. No materials can be fed into FSO during that time!
  - As soon as the measuring procedure has been completed, the display shows the relevant measuring values (figure 14).



## 5.2 View all measured data (data memory)

**Requirement:** A measurement has been performed.

- Select the button **Menu** .
- » The main menu appears on the display (figure 15).
- Now select the button **Memory** .
- » Previous measurements now appear on the display (figure 16).
- Navigate through the measured data with the buttons  and .





16 memory

id	date	time	product	%	H <sub>2</sub> O	C	status
101	2019-10-10 10:04:54		control	14.00	75.0	20.0	ErstMessung_0
102	2019-10-10 10:05:08		reference	0.00	0.7	20.0	ErstMessung_0
103	2019-10-10 10:05:54		reference	0.00	0.2	20.0	ErstMessung_0
104	2019-10-10 10:06:40		opt	11.00	75.0	20.0	ErstMessung_0
105	2019-10-10 10:06:55		opt	11.00	75.0	20.0	ErstMessung_0
106	2019-10-10 10:06:54		opt	11.00	75.7	20.0	ErstMessung_0
107	2019-10-10 10:06:51		opt/parallel	11.00	75.0	20.0	ErstMessung_0
108	2019-10-10 10:06:52		reference	0.00	-0.1	20.0	ErstMessung_0
109	2019-10-10 10:06:52		reference	0.00	0.0	20.0	ErstMessung_0
110	2019-10-10 10:06:53		reference	0.00	0.0	20.0	ErstMessung_0
111	2019-10-10 10:06:53		data	10.00	44.2	21.1	ErstMessung_0

## 5.3 Delete all measured data (data memory)

**Requirement:** One or more measurements were taken.

- Select the button **Menu** .
- » On the display appears the main menu (figure 17).
- Now select the button **User data** .
- » Options to delete measurement data and supplier data appear on the display (figure 18).
- Select the button **Delete measured data** .
- » All existing measured data on the device will be deleted.

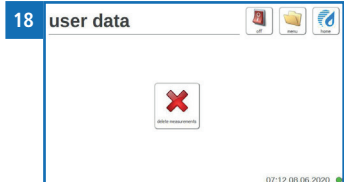
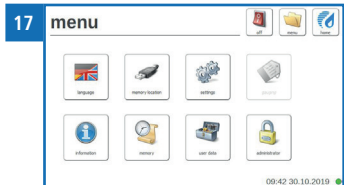

## 6. Products and calibration curves

Calibration curves are available for the following products:

Product name	Notes	Full measuring range
Durum		8 - 25 %
Oat		5 - 25 %
Maize		8 - 50 %
Rye		8 - 25 %
Spring barley		8 - 25 %
Triticale		8 - 25 %
Wheat		8 - 25 %
Winter barley		8 - 25 %
Field bean		8 - 20 %
Buckwheat		5 - 20 %
Spelt peeled		8 - 25 %
Spelt unpeeled		8 - 20 %
Forage peas		8 - 20 %
Millet peeled		5 - 20 %
Millet unpeeled		5 - 20 %
Beetle bean		10 - 40 %
Pumpkin seeds		3 - 15 %
Linseed		5 - 14 %
Rape		4 - 18 %
Rice peeled		8 - 20 %
Soybean		8 - 25 %
Sunflower		8 - 25 %
Sorghum millet		8 - 40 %
Calibration	! For calibration and control of the measuring device only !	
Reference	! Only to check the measuring device !	

On request, Schaller Messtechnik GmbH can also develop customer specific calibration curves for your product. It is also possible to enter existing calibration curves into the device subsequently.

## 6.1 Definition water content

The device displays the water content. This means that the moisture is calculated in relation to the total mass:

$$\%WG = \frac{M_n - M_t}{M_n} \times 100$$

$M_n$ : Mass of the sample with average water content

$M_t$ : Mass of the dried sample

%WG: Water content (according to the standards EN ISO 665:2001-02-01, EN ISO 712:2010-04-01 and EN ISO 6540:2010-07-15)

## 6.2 Information regarding the comparative measurement using the kiln-drying method

The device is used to measure far larger sample quantities (12 to 20 times of the kiln method). Furthermore, repeated measurements can be performed very fast in case of inhomogeneous material for a more precise calculation of the average.

Adding the sample extraction error caused by much smaller sample quantities and the proportion of non- water fugitive substances to the kiln method, the drying oven will provide an accuracy of approximately +/- 3 %. If we now compare the results of the two very different methods, differences of +/- 3% can be considered quite normal.

The standards EN ISO 665:2001-02-01, EN ISO 712:2010-04-01 and EN ISO 6540:2010-07-15 also indicate that the kiln-drying method does not provide absolute values, but only comparative values.

## 7. Data access via REST interface (OPTION)

**Requirement:** The REST interface is enabled on the device, the REST interface option has been ordered and the FSO is connected to the network.

### 7.1 Identifying the network address of the device

- Once you connect your device to the network, you should automatically receive a network address.
- » It is not possible to set a static network address directly on the device.
- Open the main menu and navigate to **Information** .
- » On the display, figure 19 appears and device information (such as network address) is shown.

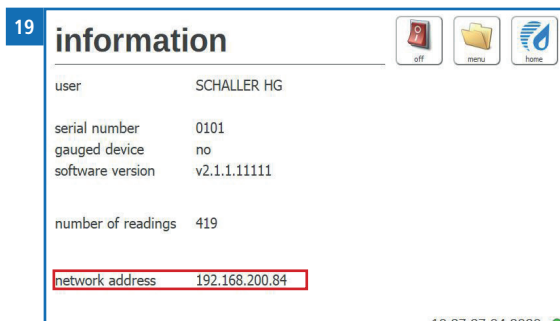



- If a network address was not given to your device, disconnect and reconnect to the network.
- » If a network address is not registered despite disconnection and reconnection, please restart the device.

### 7.2 Retrieval of measured data via browser



- To retrieve the data, the IP address of the device determined in section 7.1, the port 8081, the storage location of the data and the selection of which data is requested must be entered in the address bar of the browser.
- » The location of the data can be found on the FSO under **db**.
- » There are two options to retrieve data: the last measured value (**last**) and all measured values (**all**).
- » Example of a correct entry: 192.168.200.93:8081/db/last

## 8. Handling and menus



### 8.1 Set language

1. Select the **Menu**  button.
  - » The main menu appears on the display.
2. Select the **Language**  button.
  - » All selectable languages are now displayed (figure 20).



3. Navigate through the languages stored in the device with the  and  buttons.
4. Select your preferred language.
  - » The entry has been saved and you are back in the main menu.



### 8.1 Define memory location

1. Select the **Menu**  button.
  - » The main menu appears on the display.
2. Select the **Memory location**  button.

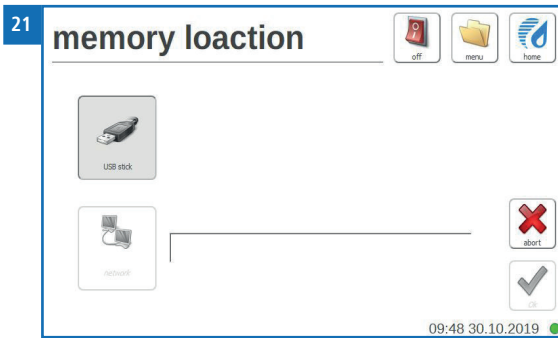
- » The memory location feature has no function in FSO.



## 8.2 Set date and time

1. Select the **Menu**  button.
  - » The main menu appears on the display.
2. Select the **Settings**  button.
  - » Settings now appear on the display.
3. Select the **Date/Time**  button.

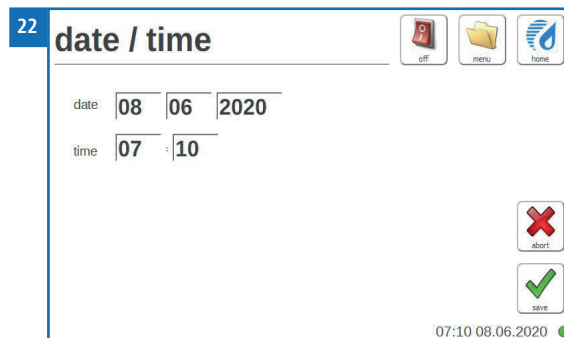



- » Now you can change date and time.

4. Confirm the change with **Save** .

» The entry has been saved and you are back in the settings.

## 8.3 Set °C/°F

1. Select the **Menu**  button.
  - » The main menu appears on the display.
2. Select the **Settings**  button.
  - » Settings now appear on the display.
3. Select the **Temperature**  button.

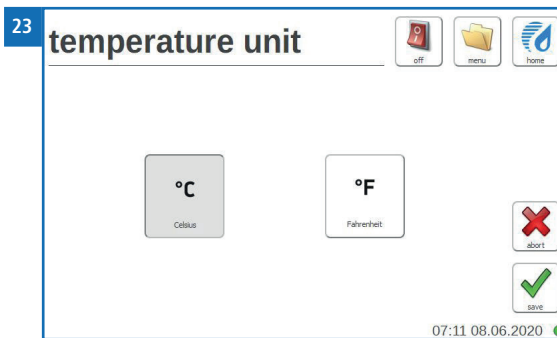



» Now you can change the displayed unit for the temperature.  
 » You can choose between Celsius °C and Fahrenheit °F.

4. Confirm the change with **Save** .

» The entry has been saved and you are back in the settings.



## 8.4 Device test

1. Select the **Menu**  button.
  - » The main menu appears on the display.
2. Select the **Settings**  button.

» Settings now appear on the display.

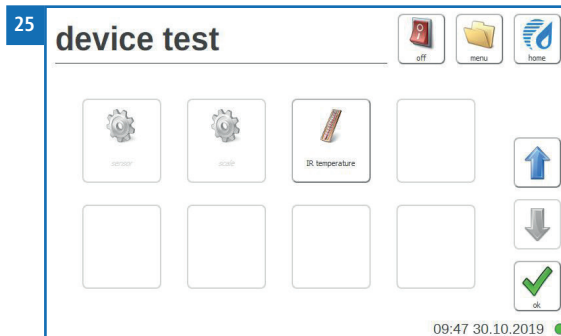
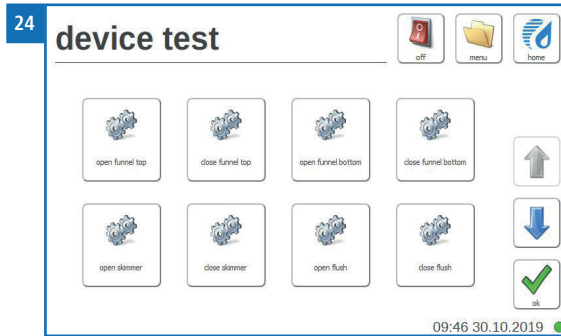
3. Select the **Device test**  button.





4. Navigate through the test options stored in the device with the  and  buttons.

With these buttons, the individual pneumatic cylinders inside the FSO measuring device can be activated manually.



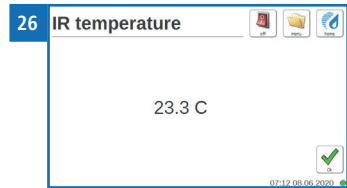

**This menu option is only reserved for service technicians and employees of Schaller Messtechnik GmbH!!**

## 8.5 IR temperature



- Select the **IR temperature**  button.
- On the display appears the currently measured infrared temperature in the measuring chamber of the device (figure 26).
- Confirm the test with **Ok** .
- » You are back in the **Device test menu**.



## 8.6 My device

1. Select the **Menu**  button.
  - » The main menu appears on the display.
2. Select the **Settings**  button.
  - » Settings now appear on the display.
3. Select the **My device**  button.
  - » Now you can enter your company name and note.
4. Confirm the changes with **Save** .
  - » The entries have been saved and you return to the settings.

## 8.7 Log file

1. Select the **Menu**  button.
  - » The main menu appears on the display.
2. Select the **Settings**  button.
  - » Settings now appear on the display.
- Select the **Log file**  button.

### 8.7.1 Log types

You have the possibility to choose between three different log types.

1. **Info** 

- » The device logs all device information.

2. **Error** 



- » The device logs all errors that occur on the device.

3. **Fatal error** 

- » The device logs only serious errors that occur on the device.
- To change the log type, select the button for the relevant log type.
- Confirm the change with **Save** .
- » The entry has been saved and you returned to the settings.

### 8.7.2 Export of existing logs

You have the option to export the logs that are already stored on the device.

- Make sure that you have a USB stick plugged into the device.
- Select the **Export**  button.
  - » The device exports the logs of the device to the USB stick.
- Confirm with **Save** .
- » The export has been completed and you returned to the settings.

## 8.8 Update

It is possible to update the software or calibration curves of the product.

1. If you receive an update from Schaller, please copy this file to an USB stick in the main directory.
2. Open the left door of the control cabinet.
3. Plug the USB stick with the Schaller update on your single-board computer.

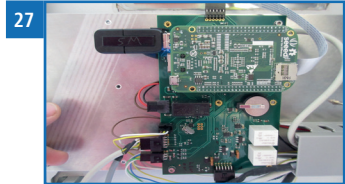

4. Select the **Menu**  button.
  - » The main menu appears on the display.

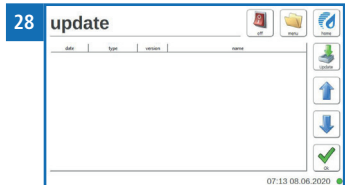

5. Select the **Settings**  button.
  - » Settings now appear on the display.

6. Select the **Update**  button.
  - » On the display, already performed updates appear in a scrollable list (figure 28).







7. Select the **Update**  button.
8. Confirm the message with **Yes**, to install the update.
9. This will restart the device.
10. Remove the USB stick from the single-board computer.
11. Close the left door of the FSO control cabinet.
  - » An update has been performed and you are back in the **Home** menu.

## 8.9 Auto-off time

- Select the **Menu**  button.
  - » The main menu appears on the display.
- Select the **Settings**  button.
  - » Settings now appear on the display.
- The **Shutdown**  button doesn't have any function for the FSO.

## 8.10 Special products



Here you can find more information on how to set the calibration type.

1. Select the **Menu**  button.
  - » The main menu appears on the display.
2. Select the **Settings**  button.
  - » Settings now appear on the display.
3. Select the **Special products**  button.
  - » You will now be asked to enter the password for the variety calibration.
  - » The password is the serial number of the device.
4. Now you can see the stored products (figure 29).
5. Select the required product
  - » The device now displays the saved calibration values (figure 30).
  - » Now you can change the calibration of the selected type.
6. Confirm the changes with **Save** .
  - » The entries have been saved and you are back in the product list.

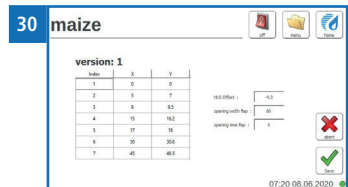
**Schaller Messtechnik GmbH accepts no liability if the calibration values are modified!!**



## 8.11 Gauging

- Select the **Menu**  button.
- » The main menu appears on the display.
- Select the **Settings**  button.
- » Settings now appear on the display.
- The **Calibration**  button doesn't have any function.

## 8.12 Information

1. Open the main menu.
- » Select the **Menu**  button.
2. Select the **My device**  button.
- » On the display appears the following information:

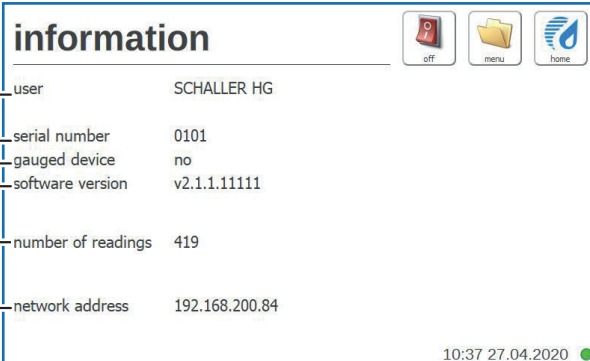

1 — user SCHALLER HG

2 — serial number 0101

3 — gauged device no

4 — software version v2.1.1.11111

5 — number of readings 419

6 — network address 192.168.200.84

10:37 27.04.2020

No	Name
1	User (see "8.6 My device")
2	Serial number
3	Calibration status
4	Software version
5	Measurement quantity
6	Network address



## 8.13 Memory

The memory menu is described in chapter "5.2 View all measured data (data memory)".

## 8.14 User data

The user data menu is described in chapter "5.3 Delete all measured data (data memory)".

## 8.15 Administrator

1. Select the button **Menu** .
  - » On the display appears the main menu.
2. Select the button **Administrator** .
  - » **This menu option is password-protected. Only service technicians and employees from Schaller Messtechnik GmbH can use it!**

## 9. Care and maintenance

By regular cleaning and maintenance you ensure that your device is kept in an undamaged condition as long as possible.

**FSO must be cleaned once every 4 weeks!**

### 9.1 Cleaning the device



#### **ATTENTION**

##### **Device damage caused by wet cleaning**

Water or cleaning products can damage the device if they get into the device.

- ▶ Dry clean only.

#### Measuring chamber

- POWER OFF your FSO using the Display or On button.
- Set the main switch to position 0.
- Close the airlock on the FSO.
- Now open the right part of your FSO measuring device.
- Remove possible remains or dirt with compressed air.

#### Display / housing surface

- Clean the display and the housing surface with a dry cloth.

## 10. Faults

If the actions listed below do not eliminate the faults or if other faults not listed here occur please, contact Schaller Messtechnik GmbH.

Fault	Cause	Remedy
Incorrect measurement	Temperature of the sample beyond the application range:: material under +5 °C or above +60 °C	Temperature of the sample over +5 °C or under +60 °C
	Temperature difference between sample and measuring device	

Fault	Cause	Remedy
	Incorrect calibration curve selected	Before starting a measurement check if the correct calibration curve (product) is set (see "6. Products and calibration curves").
	Wet or mouldy samples	The accuracy of the measurement is greatly reduced in this case.
	Stored and fermented maize from whole corn silage	May lead to a higher displayed value.
	Frozen or snow covered samples	The accuracy of the measurement is greatly reduced in this case.
	Contaminated samples	Heavily contaminated material such as long ears of barley or foreign material can strongly affect the measurement result.
Measurement not possible	Compressed air unavailable	Check if the compressed air is connected to the FSO and if the pressure is 5 bar.
Display doesn't react anymore	Crash of the operating system	Turn off the main switch for a short time and then restart the device. If the problem reoccurs, please contact Schaller Messtechnik GmbH.

## 10.1 Eventual error notifications that may occur

If the actions listed below do not eliminate the error message or if other error messages not listed here occur, please contact Schaller Messtechnik GmbH.

Message	Cause	Remedy
Sensor calibration beyond tolerance	Extreme dirt in the measuring chamber or a defective measuring chamber	
Balance calibration beyond tolerance	Material clamped in the load cell region or load cell defect	
Temperature beyond specifications	Temperature of the measured product beyond the uncalibrated application range: material below +5 °C or above +60 °C	Use samples with a temperature above +5 °C or under +60 °C
Defective load cell	Extreme contamination in the measuring chamber due to dust	
Defective infrared temperature sensor	Extreme contamination in the measuring chamber due to dust	
System error		Restart the device and repeat the process. If the error message persists, please contact Schaller Messtechnik GmbH..

## 11. Transport, storage and disposal

### 11.1 Transport



#### **ATTENTION**

##### **Device damage caused by improper transport**

The device can be damaged or irreparably destroyed by dispatch with various parcel services or the post office.

- ▶ Ship the device only with the transport protection mounted.
- ▶ Ship the device only with a professional forwarder.

Before transporting the device, please take the following actions:

1. Insert the transport protection. It must be used within the device during transportation or shipping.
2. Contact Schaller Messtechnik GmbH.

### 11.2 Storage

Store the device as follows:

- Do not store outdoors.
- Store dry and dust-free.
- Protect from sunlight.
- Avoid mechanical shocks and loads.
- Storage temperature: 0 °C bis +50 °C

### 11.3 Disposal

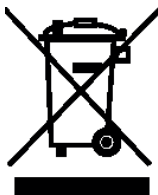

Devices marked with this symbol are regulated by the European Directive 2012/19/EU of the European Parliament and the Council of 4 July 2012 relating to waste of electrical and electronic equipment.

If the device is not used within the European Union, national disposal regulations in the country of use must be observed.

Electrical devices should not be disposed of with household waste.

Please recycle the device in an environmentally friendly way using suitable recycling systems.

## 12. Specifications of the device

### 12.1 CE declaration of conformity

# CE KONFORMITÄTSERKLÄRUNG DECLARATION OF CONFORMITY

Name/ Adresse des Herstellers: **Schaller Messtechnik GmbH**  
Name/ address of manufacturer: **Max-Schaller-Straße 99**  
**A – 8181 St. Ruprecht**

Produktbezeichnung: **Schaller**  
Product designation:

Typenbezeichnung: **FSØ**  
Type designation:

Produktbeschreibung: **Messgerät zur Bestimmung des Wassergehalts in**  
**Lebensmitteln**  
Product description **Measuring instrument for determining the water content in**  
**foodstuffs**

Das bezeichnete Produkt erfüllt die Bestimmungen der Richtlinien:  
The designated product is in conformity with the European directives:

<b>EMV - Richtlinie 2014/30/EC</b>	<b>EMC Directive 2014/30/EU</b>
<b>RoHS - Richtlinie 2011/65/EG</b>	<b>RoHS-Directive 2011/65/EU</b>
<b>Niederspannungsrichtlinie 2014/35/EU</b>	<b>Low Voltage Directive 2014/35/EU</b>
<b>Maschinenrichtlinie 2006/42/EG</b>	<b>Machinery Directive 2006/42/EG</b>

Die Übereinstimmung des bezeichneten Produktes mit den Bestimmungen der Richtlinien wird durch die vollständige Einhaltung folgender Normen nachgewiesen:

Full compliance with the standards listed below proves the conformity of the designated product with the provisions of the above-mentioned EC Directives:

**EN 61326-1:2013** Elektrische Mess-, Steuer-, Regel- und Laborgeräte - EMV-Anforderungen  
Electrical equipment for measurement, control, and laboratory use – EMC requirements

**EN IEC 63000:2019-05** Technische Dokumentation zur Beurteilung von Elektro- und Elektronikgeräten hinsichtlich der Beschränkung gefährlicher Stoffe.  
ersetzt / replaced  
**EN 50581:2012** Technical documentation for the assessment of electrical and electronic products with respect to the restriction of hazardous substances.

<b>EN ISO 12100:2011</b> <b>EN ISO 12100:2013</b>	Allgemeine Gestaltungsleitsätze - Risikobeurteilung und Risikominderung <i>Safety of machinery - General principles for design - Risk assessment and risk reduction</i>
<b>EN ISO 13857:2020-04</b>	Sicherheit von Maschinen - Sicherheitsabstände gegen das Erreichen von Gefahrstellen mit den oberen Gliedmaßen und unteren Gliedmaßen <i>Safety of machinery - Safety distances to prevent hazard zones being reached by upper and lower limbs</i>
<b>DIN EN ISO 13854:2020-01</b> <i>ersetzt / replaced</i> <b>EN 349</b>	Sicherheit von Maschinen – Mindestabstände zur Vermeidung des Quetschens von Körperteilen <i>Safety of machinery - Minimum gaps to avoid crushing of parts of the human body</i>
<b>EN ISO 13849-1</b>	Sicherheit von Maschinen – Sicherheitsbezogene Teile von Steuerungen – Teil 1: Gestaltungsleitsätze <i>Safety of machinery - Safety-related parts of control systems - Part 1: General principles for design</i>

Für das angeführte Produkt ist eine vollständige Dokumentation mit Betriebsanleitung in Originalfassung vorhanden.

*For the above mentioned product a complete documentation with manual of instruction in original version is available.*

Bei Änderungen, die nicht vom Hersteller spezifiziert sind, verliert diese Konformitätserklärung die Gültigkeit.

*In case of any changes not agreed upon with the manufacturer, this declaration of conformity loses its validity.*

St. Ruprecht a.d. Raab, 31.07.2022

  
**Schaller**  
Messtechnik / hmi-meter.com  
Schaller Messtechnik GmbH  
Maier - Schaller Straße 99  
AT - 8180 St. Ruprecht a. Raab  
www.hmi-meter.com | info@hmi-meter.com  
.....  
Bernhard Maunz  
Rechtsverbindliche Unterschrift des Ausstellers  
*Legal binding signature of the issuer*

**UK  
CA****DECLARATION OF CONFORMITY**

---

*Name/ address of manufacturer:* **Schaller Messtechnik GmbH  
Max-Schaller-Straße 99  
A – 8181 St. Ruprecht**

*Product designation:* **Schaller**

*Type designation:* **FSO**

*Product description* **Measuring instrument for determining the water content in  
foodstuffs**

The designated product is in conformity with the following directives:

- **Electromagnetic Compatibility Regulations 2016 Great Britain**
- **RoHS-Directive 2011/65/EU Directive on the restriction of the use of certain hazardous substances in electrical and electronic equipment**
- **Supply of Machinery (Safety) Regulations 2008 Great Britain**
- **Electrical Equipment (Safety) Regulations 2016 Great Britain**

Full compliance with the standards listed below proves the conformity of the designated product with the provisions of the above-mentioned Directives:

<b>EN 61326-1:2013</b>	Electrical equipment for measurement, control, and laboratory use – EMC requirements
<b>EN IEC 63000:2019-05</b> replaced <b>EN 50581:2012</b>	Technical documentation for the assessment of electrical and electronic products with respect to the restriction of hazardous substances.

<b>EN ISO 12100:2011</b> <b>EN ISO 12100:2013</b>	Safety of machinery - General principles for design - Risk <i>assessment and risk reduction</i>
<b>EN ISO 13857:2020-04</b>	Safety of machinery - Safety distances to prevent hazard zones being reached by upper and lower limbs
<b>DIN EN ISO 13854:2020-01</b> replaced <b>EN 349</b>	Safety of machinery - Minimum gaps to avoid crushing of parts of the human body
<b>EN ISO 13849-1</b>	Safety of machinery - Safety-related parts of control systems - Part 1: General principles for design

For the mentioned product, a complete documentation with manual of instruction in original version is available.

In case of any changes not agreed upon with the manufacturer, this declaration of conformity loses its validity.

St. Ruprecht a.d. Raab, 31.07.2022

 **Schaller**  
Messtechnik / [hilfsmeter.com](http://www.hilfsmeter.com)  
Schaller Messtechnik GmbH  
Maier - Schaller - Straube 99  
AT - 8180 St. Ruprecht a.d. Raab  
[www.hilfsmeter.com](http://www.hilfsmeter.com) | [info@hilfsmeter.com](mailto:info@hilfsmeter.com)  
.....  
Bernhard Maunz  
Legal binding signature of the issuer

## 12.2 Technical data

Measuring range	3 to 50 % water content (sort dependend)
Display resolution	0,01 % water content 0,1 °C temperature 0,1 kg/hl hectolitre weight
Material temperature	0 °C to +60 °C
Environmental temperature	0 °C to +50 °C
Analog output for moisture	0..50% is equal to 4..20mA
Analog output for temperature	0..60°C is equal to 4..20mA
Temperature sensor	infrared (contactless)
Temperature compensation	automatic
Sample quantity	ca. 800 ml
Volumetric flow	max. 3,2 l/min
Measuring duration	15 seconds
Power supply	24 VDC, max. 60 Watt
Cable cross section for terminal blocks	0.5 - 4 mm <sup>2</sup> bzw. 20 - 10 AWG
Display	7 inch color-touch display
Dimensions (WxDxH)	860 x 700 x 260 mm
Weight	32 kg
Compressed air connection	Ø 4 mm, 5 bar +/-0,5 bar
Device IP rating	IP 40

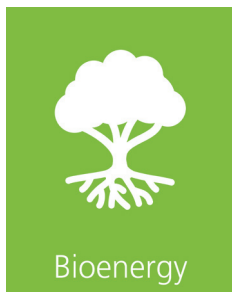
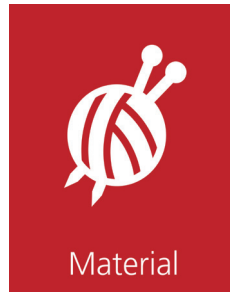

Schaller Messtechnik develops, produces and sells professional moisture meters and turnkey solutions.

**Schaller Messtechnik GmbH**

Max-Schaller-Straße 99, A - 8181 St. Ruprecht an der Raab

Tel +43 (0)3178 - 28899 , Fax +43 (0)3178 - 28899 - 901

info@humimeter.com, www.humimeter.com